

# Cement Connections 'R' Class

10	9	8	7	6	5	4	3	2	1
----	---	---	---	---	---	---	---	---	---

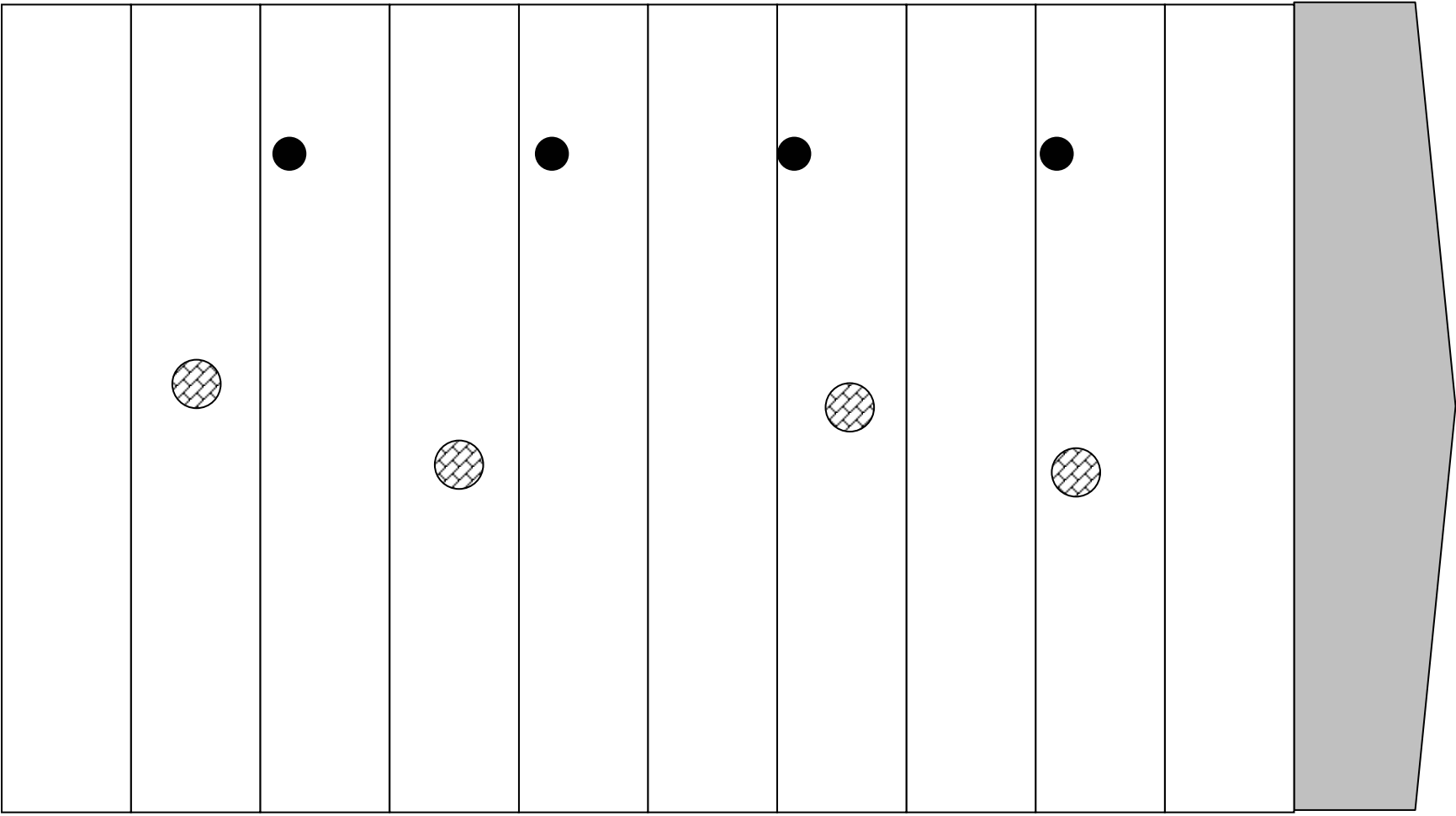

<b>Cement Fittings (Loading)</b>	
Inner Dia	470mm
PCD	520mm
No of bolts	12
Dia of bolts	16mm c/s



<b>Cement Fittings (Exhausting)</b>	
Outer Dia	350mm
PCD	314mm
No of bolts	6



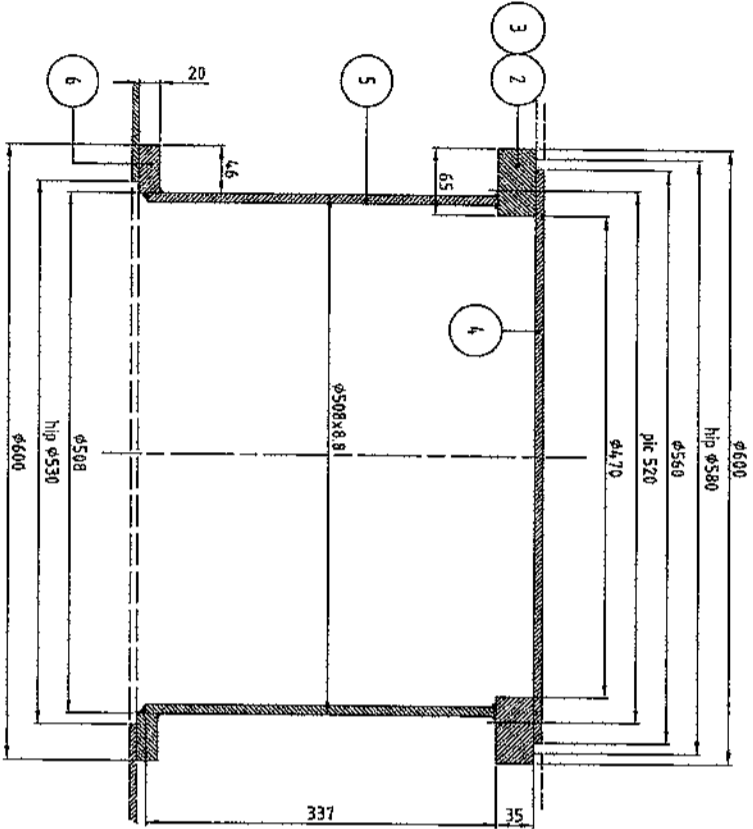
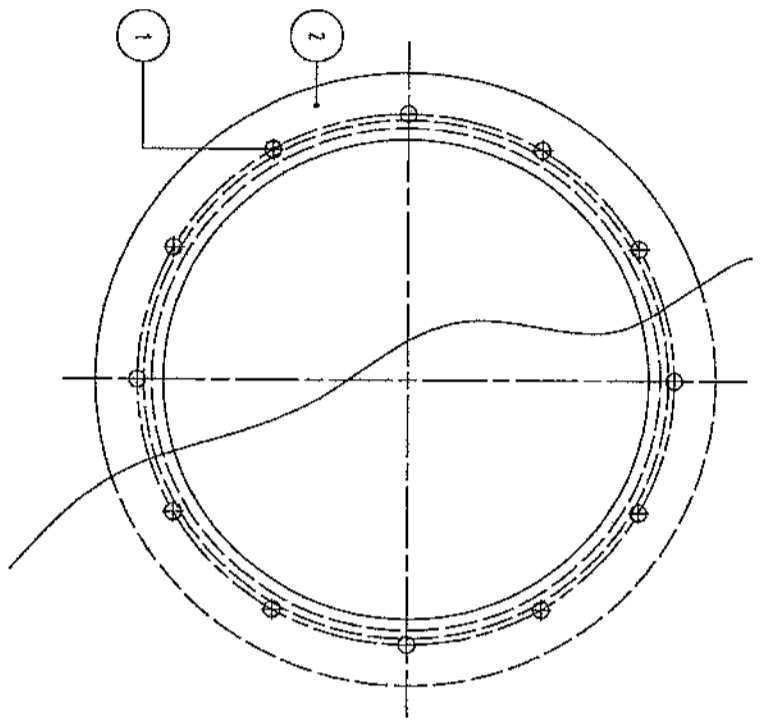

A. RAIDER

Pos	Aant.	Art.nr.	Omschrijving	Netto afmeting(en)	Opmerking	Tekenners
6	1	108418	SijpL.B 20x 600- 6508 GRA SWHC			
5	1	112718	Bus 508,0x 8,8 onlsw	337		
4	1	103286	Mangaldaksel 8mm			
3	1	103285	Mangalring 8mm neoprene			
2	1	103284	Mangalring 12gats			
1	12	102004	V2Jamb Mix 30 0,8 EV DM17991			

REV.	REV.DATE	DRW.	DESCRIPTION
A2	3-12-03	MI	BUS GEWUJZID
A	3-12-03	MI	BUS GEWUJZID

  

GENERAL TOLERANCE: NEN-ISO 2768-mK		MACHINING SURFACE ROUGHNESS: NEN3832		WELDING: a=1/4 (min. a=3.5)	
RODEN - +31 (0)50-5015855 - FAX +31 (0)50-5016775 - HOLLAND					
RODEN STAAL BV					
R CLASS					
Stortgat 470 L=337					
Voor uitvoering					
MBEW.		LABOR		STATUS	UIT
VORDERW.		LABOR		STATUS	IN
INHOOP		LABOR		STATUS	
MAGAZIN		LABOR		STATUS	

CUSTOMER	R CLASS
DESCRIPTION	Stortgat 470 L=337
SCALE	1:5
DATE	15-4-02
DRW.	MI
ORDN.	
Offm.	
PROJECT Nr.	
DRAWING Nr.	1063556.001A

A. RAYEEL

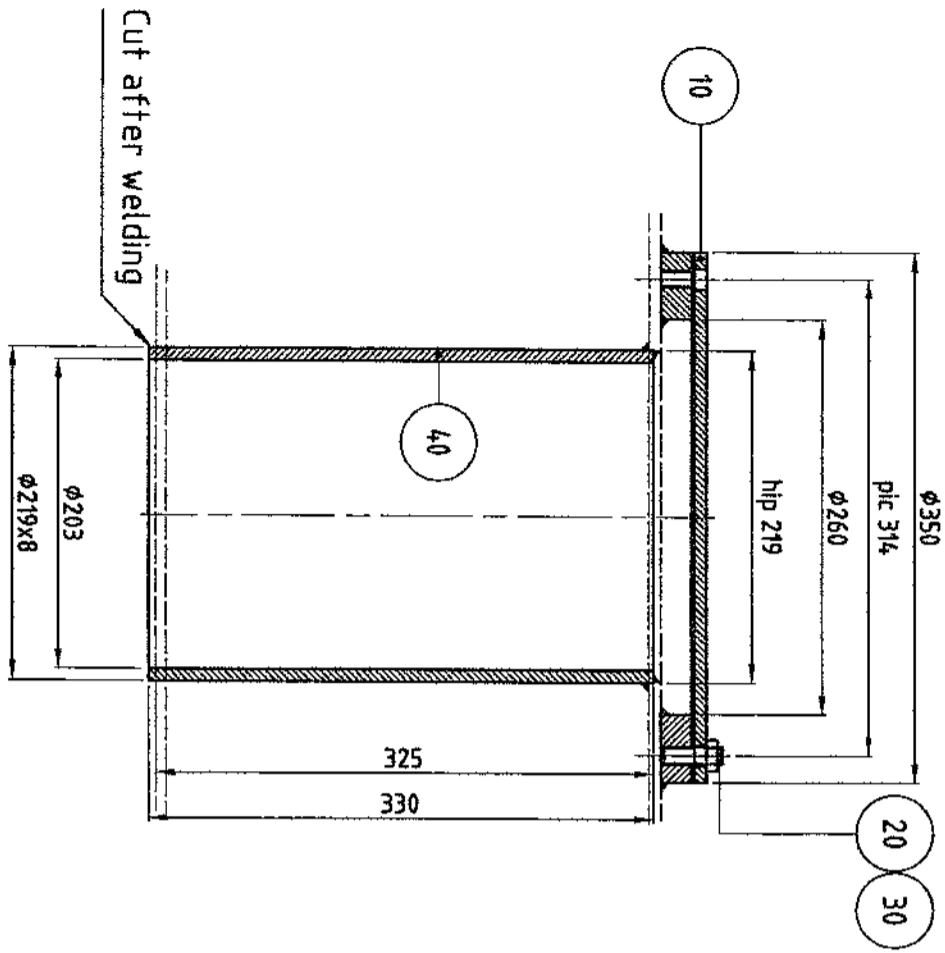
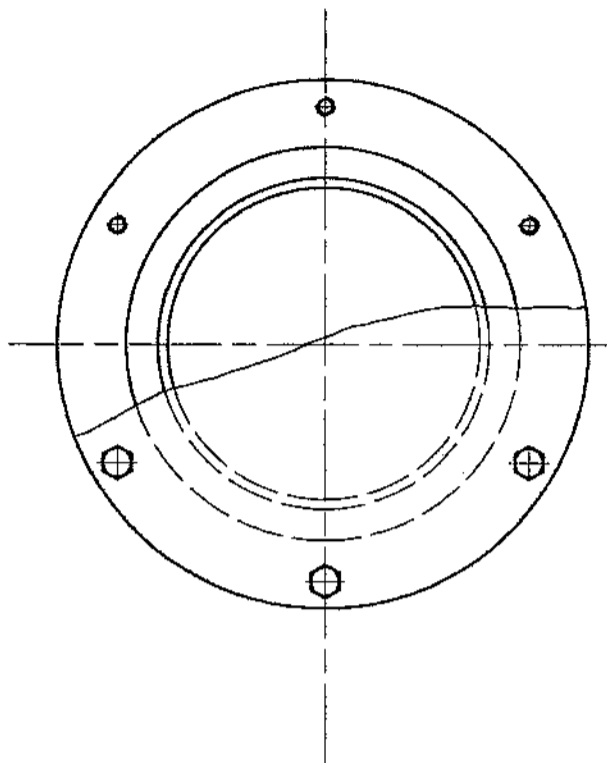

A REVISION

Pos	Qty	Art.no.	Description	Material	Nett dimension	Remark	Dwg numbers
40	1	108096	Buis 219,1x 8,0 gel. onbew		330		
30	6	108453	Moer M12 rvs A4-70 Din934	RVS A4			
20	6	108464	Draadst. M12x1mtr rvs A4	RVS A4	45	Borging Locktite nr6	
10	1	114924	Handgat Ø350mm 6xM12 dr.gaten			Met M12 draadgaten !	

GENERAL TOLERANCE: NEN-ISO 2768-mK		MACHINING SURFACE ROUGHNESS: NEN3634		WELDING: a=1/2t (min. a=3,5)	
A	18-7-2006	MI		ASSEMBLING	
				HYDRAULIC	
				WELD. LARGE	
				WELD. SMALL	
				IRONW. LARGE	
				IRONW. SMALL	
				MACH-HANDLE	
				PRE-PROCESS	
				STORE	
				STATUS:	OUT IN

REV. A3	REV. DATE	DRW.	DESCRIPTION	DRACHTEN - +31 (0)512-591000 - FAX +31 (0)512-591050 - HOLLAND	RODEN STAAL BV
COPYRIGHTS					
CUSTOMER			R CLASS		
DESCRIPTION			Stortgat Ø 203 L=330		
SCALE	1:5	ORDN.	PROJECT N°.	DRAWING N°.	
DATE	15-11-2005	OFFN°.		116326.001A	
DRW.	RG				